

Length is measured from where the surface is assumed to be, to the end of the screw. Therefore, pan head screws are measured from under the head, and flat head screws are measured overall.

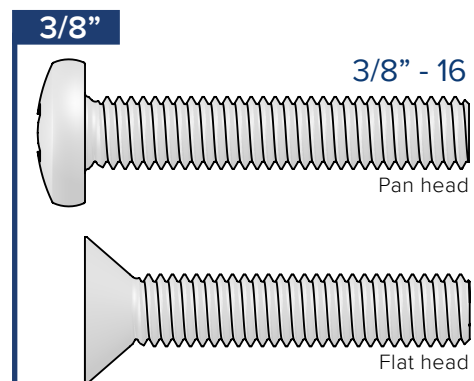
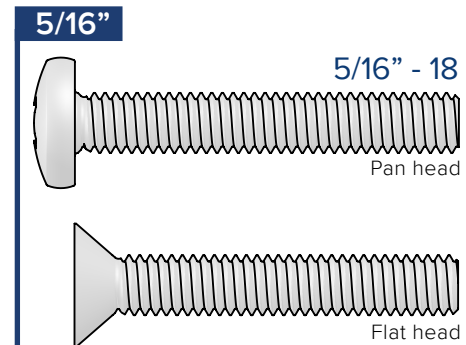
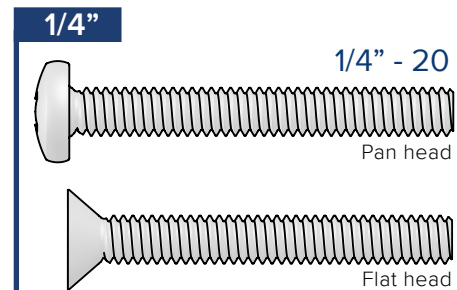
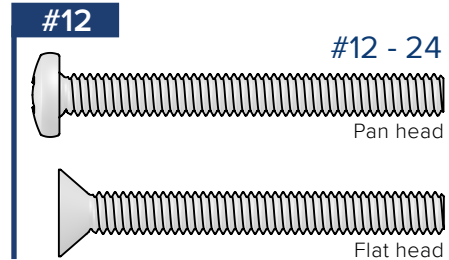
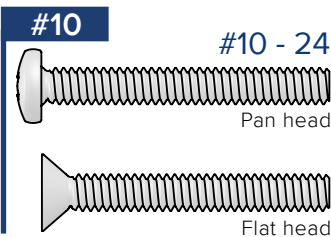
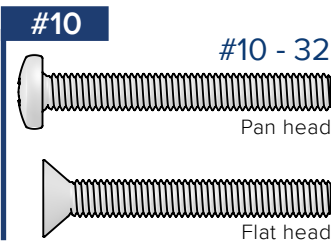
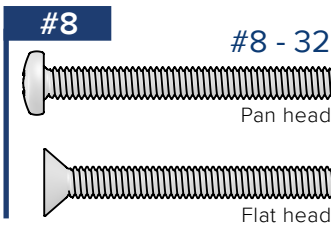
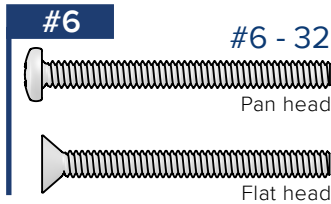
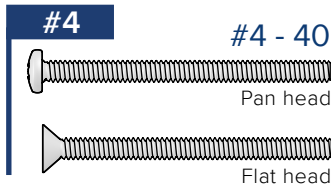
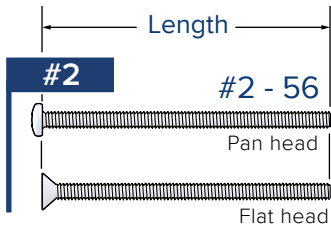
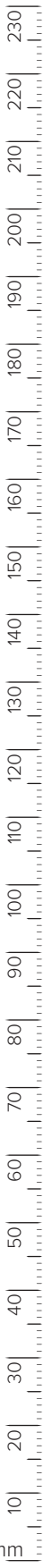

IMPORTANT: Make sure to print this chart to Actual Size (no scaling). After printing, measure the ruler in the margin to ensure correct scale. See boltdepot.com/tools for more details.